

LF11

Absolute Linear Magnetic Encoder System

SMALL
FOOTPRINT

LOW LATENCY

BISS C
OUTPUT

LF11 is a board-level absolute linear magnetic encoder system designed for motion control applications as a position and velocity control loop element.

The miniature design and low weight of the encoder system make it suitable for applications with limited space in relatively clean environments.

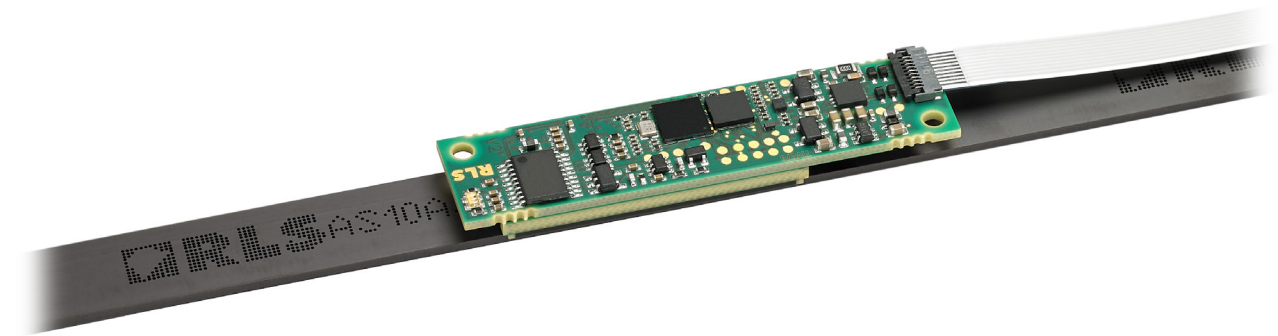

Features and benefits

- ▶ True absolute system
- ▶ Suitable for highly dynamic control loops
- ▶ Small footprint 50 × 12 × 5 mm
- ▶ Resolutions up to ~0.244 μm
- ▶ Axis lengths up to 16.3 m
- ▶ Speeds up to 7 m/s at 0.976 μm resolution
- ▶ BiSS C unidirectional



SMT PICK AND PLACE



SPACE CONSTRAINT
APPLICATIONS



LINEAR MOTOR



MEDICAL



ASSEMBLY LINES

General information

The LF11 board-level encoder system provides true absolute position information immediately after power-up. The measuring standard is a magnetic scale which is magnetised with two tracks. The incremental track is magnetised with North/South 2 mm poles and the absolute track is magnetised with a pseudo-random binary sequence.

The readhead consists of a Hall sensor array that reads the absolute track and an AMR sensor that reads the incremental track. The raw data is merged by the interpolator and the microcontroller unit. The position information is additionally processed in the FPGA, which enables low latency and short response time (1 bit) in the BiSS communication protocol. Diagnostic information is available via the communication protocol and the multicolor status LED.

The readhead allows connection through the FFC low-profile connector with a locking mechanism.

The miniature design offers the possibility to integrate the LF11 encoder systems into space-constrained and relatively clean applications, such as various medical devices, SMT pick-and-place machines, lighting fixtures, XYZ motion stages and similar.

The LF11 readhead can be optionally protected with a conformal coating film to protect the exposed electronic components from dust and moisture to a certain degree.

Choose your LF11 absolute magnetic encoder system

The LF11 readhead is compatible with the RLS absolute scale AS10. You can select the length of the AS10 scale up to 16.3 m. To ensure safety and reliability, the scale can be optionally covered with a protective stainless steel foil or installed using TRS track system.

LF11 readhead

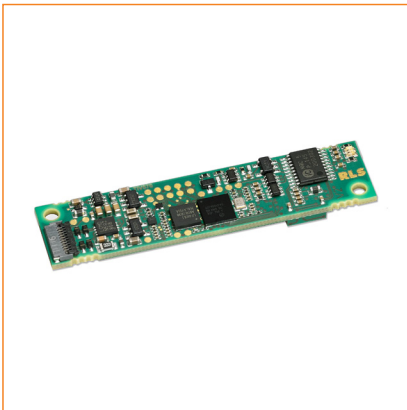

AS10 magnetic scale



More about the AS10 magnetic scale can be found in the ASD01 at [RLS Media center](#).

TRS track system

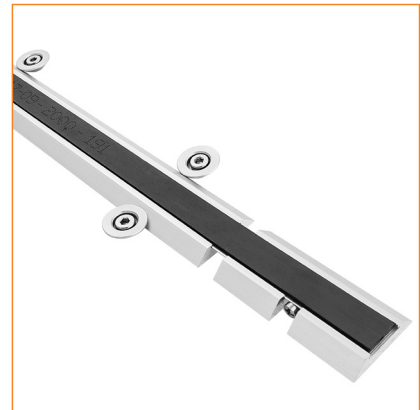

More about the TRS track system can be found in the ASD01 at [RLS Media center](#).

Storage and handling

Storage temperature



-20 °C to +85 °C

Operating temperature



0 °C to +55 °C

Humidity



Up to 70 % non-condensing

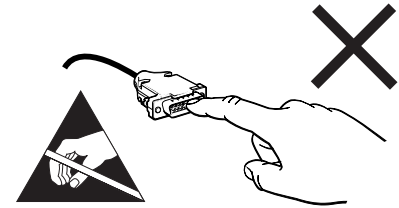
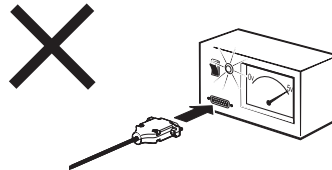
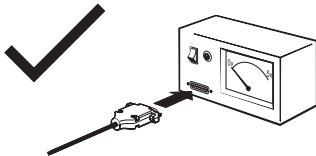

The encoder is a mechanically sensitive component. Handle it by its edges, touch it lightly, minimize pressure and eliminate bending while maintaining a secure grip to prevent falls. Maximize cleanliness. When not in use, place it in an ESD protective packaging (box or tray).

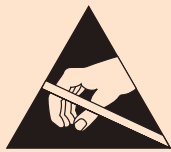

Readhead is ESD sensitive - handle with care.

Do not touch electronic circuit, wires or sensor area without proper ESD protection or outside of ESD controlled environment.

Packaging

Less than 24 readheads are individually packed in antistatic boxes. For quantities of 24 pieces or more, the readheads are packed in antistatic trays (see table below). The trays are packed together in a cardboard box (10 trays per box).

Part	Tray size	Box size
LF11 readhead	24 units per tray	10 trays per box

Dimensions drawing

Dimensions and tolerances are in mm.

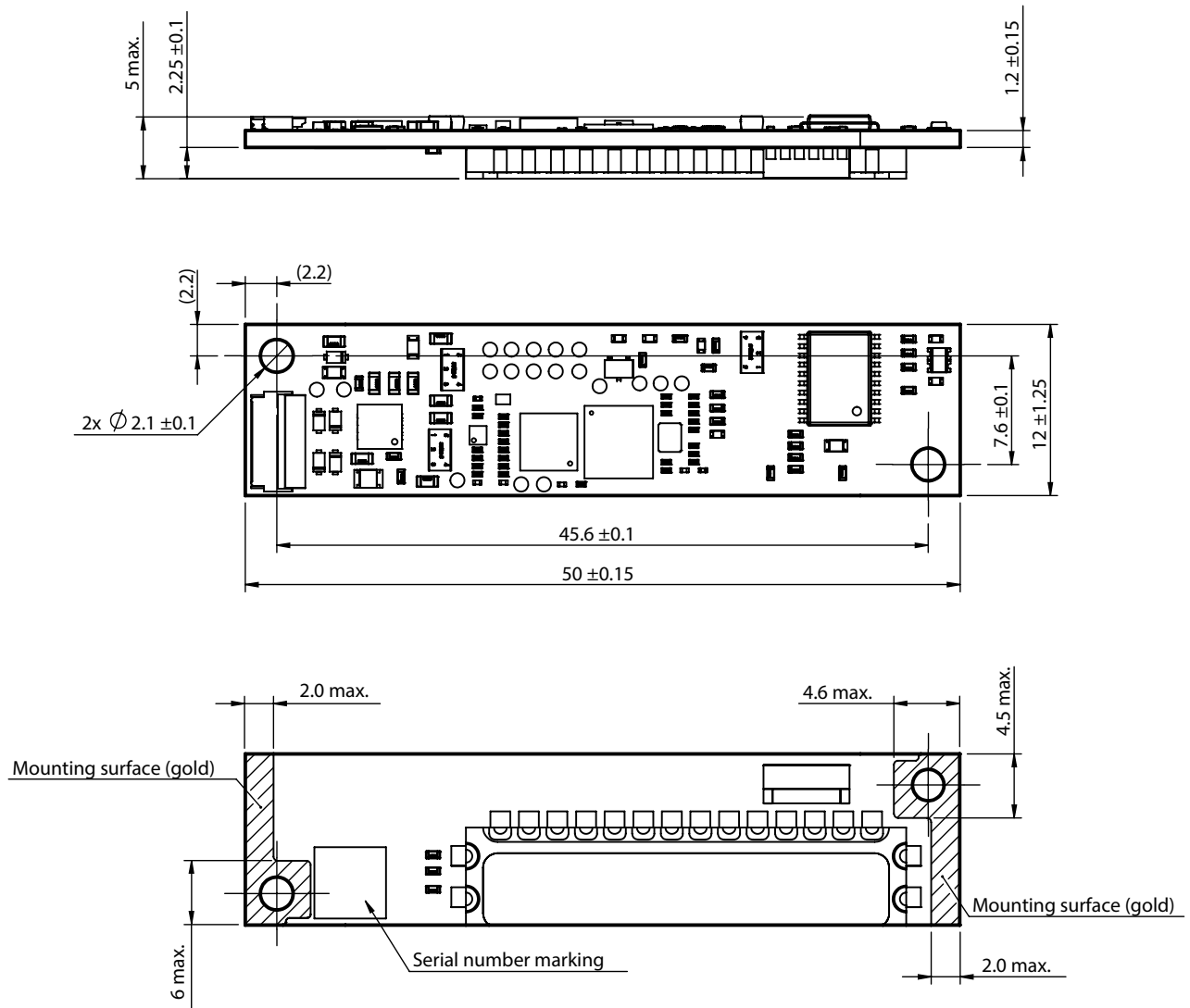

General tolerances: ISO 2768 m K

3D model available for download at [LF11 website](#).

Installation instructions

Accurate installation is the key to achieve specified performance of the encoder system. Improper mounting of the magnetic scale, readhead, or both may cause the magnetic encoder system to malfunction.

The magnetic encoder system must be installed and mounted in strict compliance with the installation dimensions and tolerances given on [page 4](#) and in the ASD01 at [RLS Media center](#).

It is essential that the air gap and lateral offset between the readhead and the magnetic scale is maintained over the entire measuring range.

The magnetic encoder system must be used in accordance with the specified degree of protection. The following factors must be taken into account: IP protection class, operating temperature, external magnetic field, humidity level, mechanical load and EMC compatibility.

When the magnetic scale is applied with an adhesive tape, it is recommended that it is mounted in a straight groove to avoid bending or shifting.

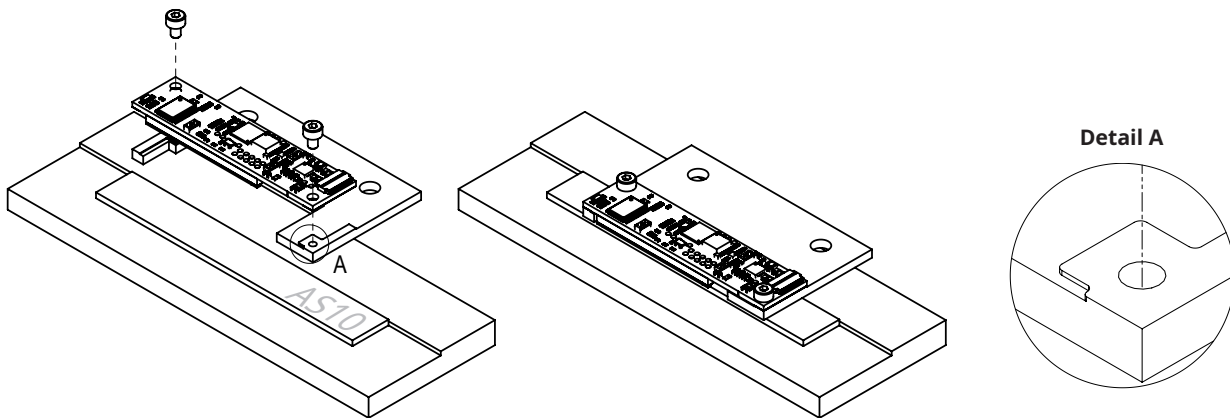

Recommended use of M2 fasteners with washers. For more information see [Table of recommended fastener tightening torques](#) at [RLS Media center](#).

- The magnetic encoder system is sensitive to external magnetic fields. The magnitude of the influence on the magnetic encoder system depends on the magnitude and direction of the external magnetic field. In particular, the rapidly changing stray magnetic fields affect the system and can change its function. Magnetic field strength within 1 mT reduces the accuracy of the system. Field strengths greater than 1 mT cause the system to malfunction and, as a result, the readhead reports an incorrect absolute position with the active error status. Magnetic field strengths greater than 25 mT will cause irreparable damage to the magnetic scale and must be replaced.
- The flex cable requires adequate strain relief to ensure the integrity and avoid side forces that can loosen or damage the connector. Ensure that a distance of >0.1 mm is maintained between the PCB-A and the mounting bracket (surrounding metal objects).
- Only the mounting surfaces (as shown on the right) may come into contact with the mounting bracket. The LF11 is a PCB-A level encoder system. The PCB assembly is open and does not have an IP rating, therefore adequate protection must be provided for the environment in which the product is used.
- The encoder system and flex cable must be properly integrated into the application to minimize electromagnetic interference.

To avoid damage to the PCB, do not use countersunk fasteners.



Technical specifications

System data

Pole length	2 mm		
Maximum measuring length	16.3 m		
System accuracy	±30 µm/m at 0.2 mm ride height For more information about the accuracy of AS10 magnetic scale please refer to ASD01 available at RLS Media center .		
Hysteresis	<2 µm at 0.2 mm ride height		
Repeatability	<1 µm		
Available resolutions [µm]	0.244140625	0.48828125	0.9765625
Maximum speed [m/s]	2	4	7
Sensor and position processing latency	<5 µs		

Electrical data

Power supply	5 V ±5 %		
Reverse polarity protection	Yes		
Set-up time after switch-on	<1s		
Current consumption (without load)	<160 mA at 5 V power supply		
Max. flex cable length	610 mm		

Mechanical data

Mass	3 g		
Connector	FH34SRJ-10S-0.5SH (50), RoHS approved		

Environmental data

Temperature	Operating	0 °C to +55 °C
	Storage	-20 °C to +85 °C
EMC Emission	EN IEC 61000-6-4:2019	
Vibrations (55 Hz to 2000 Hz)	IEC 60068-2-6:2008	
Shocks (6 ms)	IEC 60068-2-27:2009	
Humidity	Up to 70 % non-condensing	
Radiated, radio-frequency, electromagnetic field immunity test	EN IEC 61000-4-3:2020	
External magnetic field during the operation (readhead)	<0.5 mT	

Electrical connections

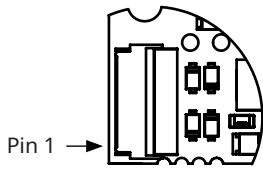

Connector:
FH34SRJ-10S-0.5SH(50)

If conformal coating is applied, the output connector is not protected by the coating.

Pinout

Pin	BiSS C output
1	GND
2	MA +
3	MA -
4	GND
5	$V_{in} + (+5 V)$
6	$V_{in} + (+5 V)$
7	GND
8	SLO -
9	SLO +
10	GND

Status indicator LED







After mounting the magnetic scale, the readhead can be easily adjusted on the machine using the set-up LED indicator.

The LED provides visual feedback on signal strength, error status, and is used for setup and diagnostics.

Flashing LED indicates that power is being supplied to the encoder, but communication has not been established.

Error status has higher priority than Warning status in LED signaling.

LED signaling may differ from the encoder status signaled by the controller.

LED Status	Status	Description
 Green	Normal operation	Position data is valid.
 Orange	Warning	Position data is valid. The internal temperature is near operational limits.
 Red	Error	Position data is not valid. Possible causes: <ul style="list-style-type: none"> The distance between the readhead and the magnetic scale is too large. Signal lost. The readhead is out of alignment with the magnetic scale or the magnetic scale is demagnetised. Incorrect orientation of the readhead and the magnetic scale. The internal temperature is out of operational limits. The encoder speed is out of operational limits.
 Fast flashing red	Error	Position data is not valid. Internal system error. Non-recoverable.
 Slow flashing red or green	-	The communication has not been established.
 No light	No power supply	/

During installation, the readhead must be moved for more than 10 mm over the magnetic scale to see the current encoder status on LED. The change from red to green color LED indicates a correctly installed encoder. After successful installation, perform a power off/on cycle.

The LED signal statuses listed in the table above do not indicate non-optimal installation of the readhead, such as accuracy outside the specified range.

If the readhead reports an error during operation as a result of incorrect decoding of absolute position on the magnetic scale, this indicates a serious issue. Serious issues are a wrong installation or damaged magnetic scale. To determine the root cause of the problem, please do the following:

- Verify the installation that is in accordance with the LF11 specification (ride-height, lateral offsets and yaw/pitch/roll tolerances)
- If possible, check the error spot on the magnetic scale with the magnet viewer for the abnormal pattern in the magnetic code

Once the root cause is determined, please perform the power OFF-ON cycle of the readhead or move it for 10 mm over the scale.

The same behavior applies when the application in which the LF11 readhead is installed forces the readhead to leave the magnetic scale (no overlapping). In this case, when the readhead starts to overlap again from either side of the magnetic scale, the error disappears once the readhead travels 10 mm of valid position.

Output type

BiSS C uni-directional interface

Specifications

Type of interface	BiSS C unidirectional (point to point)
Signal level	RS422
Maximum MA clock frequency	5 MHz
Minimum MA clock frequency	200 kHz
Length of position data	26 bit (the position data is fixed regardless of the selected resolution); LSB = 2^0 (the value in μm depends on the chosen resolution) At resolutions lower than 13 bits, the absolute position is shifted to the right (right-aligned) - no padding bits. The active LSB bit always occurs before the error bit.
Length of ACK	1 bit (fixed)
Length of status data	2 bit (error and warning)
Length of CRC data	6 bit (inverted bit output - polynomial 0x43), MSB first
Position data encoding	Pure binary
CDS	Always zero
Latency time	0.8 μs at 5 MHz MA freq.; otherwise 4 MA clock periods
Timeout (t_m)	$\geq 10 \mu\text{s}$
Maximum read repetition rate	45 kHz at MA = 5 MHz

Timing diagram

Encoder latches position value

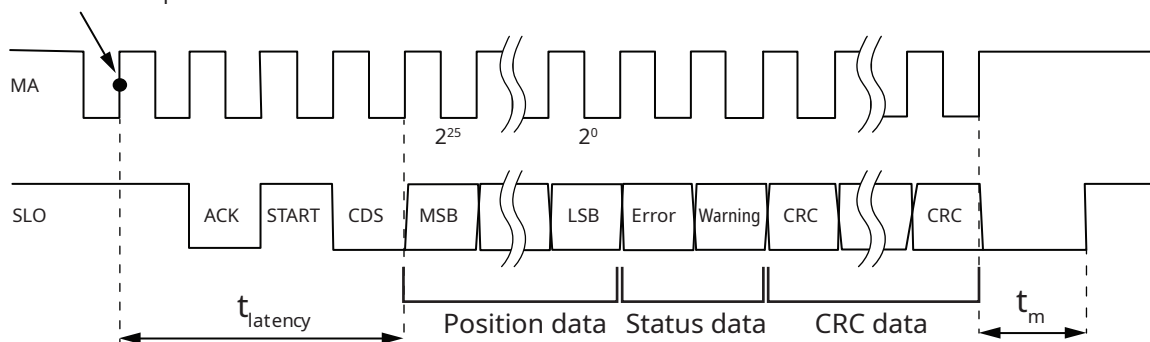

Status data

Bit	Type	»L«	»H«	Possible reason for failure
E	Error	Position data is not valid.		See LED status for error.
W	Warning	Position data is valid.	Position data is valid.	See LED status for warning.

The encoder will start responding in accordance with the BiSS C communication protocol after set-up time is passed.

Some controller interfaces do not support the input of a resolution value with more than 3 digits (e.g. only 244 nm). In this case, please contact us or the manufacturer of the controller.

Part numbering

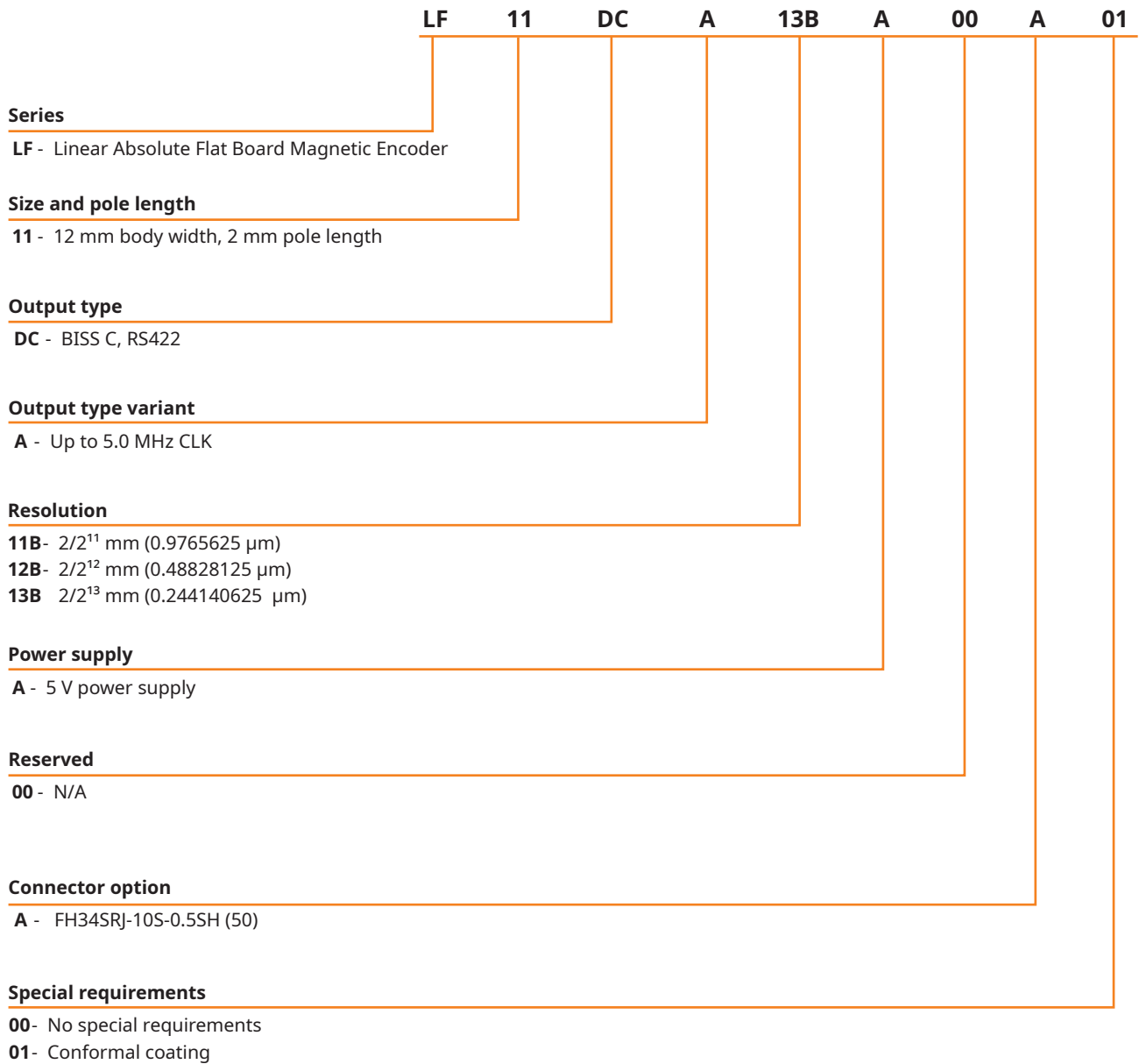

Table of available combinations

Series	Size and pole length	Output type	Output type variant	Resolution	Power supply	Reserved	Connector option	Special requirements
LF	11	DC	A	11B / 12B / 13B	A	00	A	00 / 01

Accessories



USB encoder interface

(BiSS C and SSI)

E201-9S

To use the E201 with LF11, an additional adapter from FFC to DB-9 type is needed (not provided by RLS).



Flex cable

ACC050 - 76.2 mm long

ACC051 - 152.4 mm long

ACC052 - 304.8 mm long

ACC053 - 609.6 mm long

Cable specifications

FJH-10-D-03.00-4 (ACC050)

FJH-10-D-06.00-4 (ACC051)

FJH-10-D-12.00-4 (ACC052)

FJH-10-D-24.00-4 (ACC053)

Conductor	Tin plated copper
Number of conductors	10
Conductor resistance	1000 Ω /km
Temperature range	-30 °C to +80 °C
Minimum bending radius	20 mm
RoHS compliant	Yes

Head office

RLS Merilna tehnika d. o. o.

Poslovna cona Žeje pri Komendi
Pod vrbami 2
SI-1218 Komenda
Slovenia

T +386 1 5272100
E mail@rls.si

www.rls.si

Global support

Visit our [website](#) to contact your nearest sales representative.

Document issues

Date	Issue	Page	Description
13. 10. 2020	1	-	New document
29. 7. 2021	2	-	General improvement of the document
21. 2. 2022	3	-	AS scale specifications removed
16. 2. 2023	4	4	Dimensions drawing amended
11. 9. 2023	5	9	Specifications amended
		10	Status data amended

This product is not designed or intended for use outside the environmental limitations and operating parameters expressly stated on the product's datasheet. Products are not designed or intended for use in medical, military, aerospace, automotive or oil & gas applications or any safety-critical applications where a failure of the product could cause severe environmental or property damage, personal injury or death. Any use in such applications must be specifically agreed to by seller in writing, and is subject to such additional terms as the seller may impose in its sole discretion. Use of products in such applications is at buyer's own risk, and buyer will indemnify and hold harmless seller and its affiliates against any liability, loss, damage or expense arising from such use. Information contained in this datasheet was derived from product testing under controlled laboratory conditions and data reported thereon is subject to the stated tolerances and variations, or if none are stated, then to tolerances and variations consistent with usual trade practices and testing methods. The product's performance outside of laboratory conditions, including when one or more operating parameters is at its maximum range, may not conform to the product's datasheet. Further, information in the product's datasheet does not reflect the performance of the product in any application, end-use or operating environment buyer or its customer may put the product to. Seller and its affiliates make no recommendation, warranty or representation as to the suitability of the product for buyer's application, use, end-product, process or combination with any other product or as to any results buyer or its customer might obtain in their use of the product. Buyer should use its own knowledge, judgment, expertise and testing in selecting the product for buyer's application, end-use and/or operating environment, and should not rely on any oral or written statement, representation, or samples made by seller or its affiliates for any purpose. EXCEPT FOR THE WARRANTIES EXPRESSLY SET FORTH IN THE SELLER'S TERMS AND CONDITIONS OF SALE, SELLER MAKES NO WARRANTY EXPRESS OR IMPLIED WITH RESPECT TO THE PRODUCT, INCLUDING ANY WARRANTY OF MERCHANTABILITY OR FITNESS FOR ANY PARTICULAR PURPOSE, WHICH ARE DISCLAIMED AND EXCLUDED. All sales are subject to seller's exclusive terms and conditions of sale which, where the seller is (a) RLS Merilna tehnika d. o. o., are available at <https://www.rls.si/eng/salesterms>, (b) Renishaw, Inc., are available at <https://www.renishaw.com/legal/en/-42186>, or (c) another person, are available on request, and in each case, are incorporated herein by reference, and are the exclusive terms of sale. No other terms and conditions apply. Buyer is not authorized to make any statements or representations that expand upon or extend the environmental limitations and operating parameters of the products, or which imply permitted usage outside of that expressly stated on the datasheet or agreed to in writing by seller.

RLS Merilna tehnika d. o. o. has made considerable effort to ensure the content of this document is correct at the date of publication but makes no warranties or representations regarding the content. RLS Merilna tehnika d. o. o. excludes liability, howsoever arising, for any inaccuracies in this document. © 2023 RLS d. o. o.